



SERDI

MICRO magnet

CYLINDER HEAD CENTER

Multi-angle seat cutting unit with precision dual centering system. Ideal for low volume motorcycle and for automotive shops on small diameters.

Compact cylinder head center with powerful pneumatic engine and 360° rotation cylinder head clamping system.



MICRO magnet

User friendly ergonomic design.

Easy tool setting, multi-angle seat machining and seat pocket counterboring.

Uses original SERDI tooling for machining accuracy and economical upgrade to bigger equipment.

Machining capacity from 0.63" / 16 mm to 2" / 50 mm.

Direct magnetic clamping on head center's steel plate.

Rugged and heavy construction: 15.4 lb / 7 kg) for rigidity, durability and dependability.

Precision Vernier for consistent cutting depth control. 0.600" / 15 mm total travel, 0.0008" / 0.02 mm increments.

8 degrees spindle tilt accommodate canted and compound angle valves.

Dual plane and spherical air cushions for perfect concentricity

CYLINDER HEAD CENTER

Fully 360° rotative cylinder head support

Integrated pneumatic vacuum tester for valve seat sealing

Available with a dedicated tool sharpener

CYLINDER HEAD CENTER TECHNICAL FEATURES

Space requirements

Length	mm / inch	1900/74.8
Width	mm / inch	1100/43.7
Height	mm / inch	2300/90.5

Max cylinder head dimensions

Length	mm / inch	850/34
Width	mm / inch	250/9.8
Height	mm / inch	250/9.8

Pneumatic vacuum tester

Pressure	bar/psi	1/14.5
----------	---------	--------

Connections

Power supply	2.5kVA-230V-AC-1Ph-50/60 Hz
Pneumatic supply	bar / psi 6/87
Max. air flow	l/mn -CFM 300/11
Net weight approx.	kg / lbs 150/330

CYLINDER HEAD SUPPORT

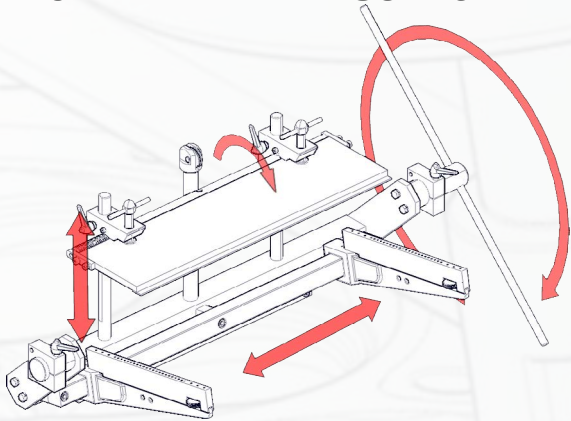

PNEUMATIC ENGINE

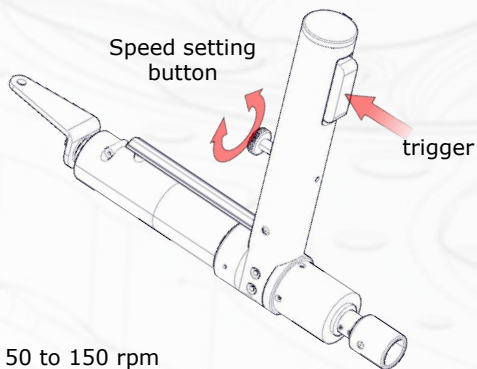

speed: 50 to 150 rpm

micro magnet TECHNICAL FEATURES

Dimensions

Length	mm / inch	253.5/10
Width	mm / inch	135/5.3
Height	mm/inch	208/8.2
Weight	kg / lbs	7/15.4

Spindle

Sphere-cylinder travel (radius)	mm / inch	5/0.10
Spindle stroke	mm / inch	15/0.6
Spindle rotation speed	rpm	50 to 150

Machining capacity

mm	16 to 50
inch	0.63 to 2

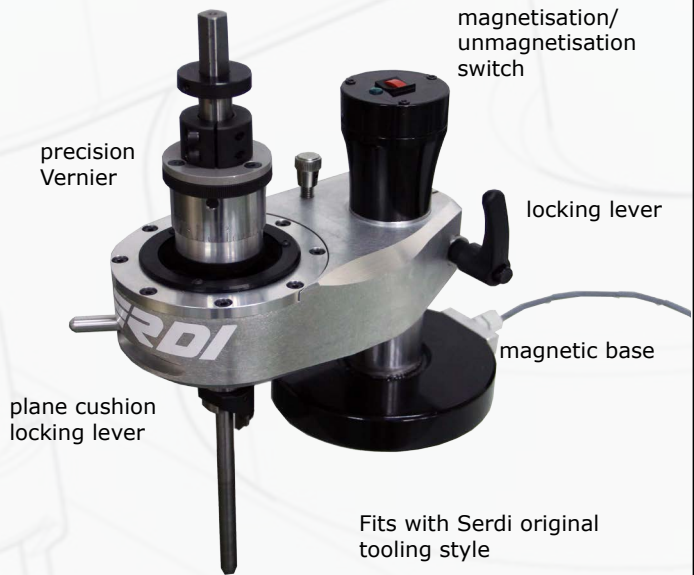

Fits with Serdi original tooling style

DUAL AIR CUSHION

horizontal air cushion

spherical air cushion

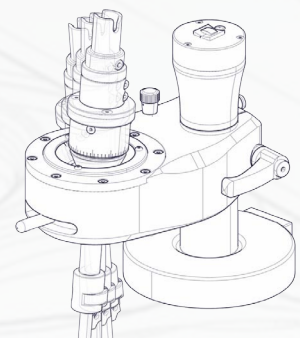
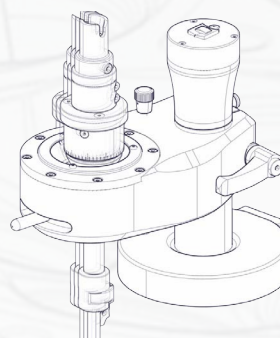

MACHINES SERDI S.A.

23, avenue des vieux moulins
B.P. 380
74012 Annecy Cedex
France

 00 33 4 50 65 63 00
Fax: 00 33 4 50 52 99 92
www.serdi.com
Email: export@serdi.com

SERDI CORP.

1526 Litton Drive
Stone mountain
Georgia 30083
USA

 (770) 493 82 20
Fax: (770) 493 83 23

Your distributor: