



Winona Van Norman®

engine rebuilding
equipment

balancing

block
machining

boring

cleaning

crankshaft

cylinder head
machining

flywheel
grinders

honing

motorcycle
small engine

surfacing



Flywheel Grinders

Machines, Parts and Supplies

Since 1888 – North America's leading supplier of engine and engine component machine shop equipment.

Cleaning machines to flywheel grinders, and everything in between. With more than 40 categories of machines and tools, Winona Van Norman offers the widest range of machine shop equipment of any source.

But wide selection is not the main reason to call us when you want to start, expand, or improve a shop. The main reason is that we stand behind each of our products with a system of total support.

At Winona Van Norman, we do more than supply equipment. We help you make your shop succeed! We help you to get operating fast. Shop planning for smooth workflow, machine installation, on-site training by our representatives and technicians help you get into production quickly.

When you select equipment from Winona Van Norman, you start operating sooner to earn profits faster. New ideas in shop productivity, come from you, our customers and our engineering staff improving the design of equipment by using ideas gained in testing. These innovations provide new solutions of great value.

Original parts from the original manufacturer.

Rapid, reliable service support. Whatever your location, parts and service are available fast. Trained personnel and our technical staff are at your disposal with a toll free call to us.

More than a business Winona Van Norman believes in people and community. Company President, Linda Weir-Enegren founded Rainbows United in 1972. Rainbows has been dedicated to enhancing the lives of children with disabilities through customized services designed in partnership with the families.

This year Rainbows United will serve over 1000 disabled children. It is estimated that

in its 37 years of operation the center has directly impacted the lives of more than 100,000 people, including the children and their immediate families. Rainbows United was used as a model by Japan in creating their own education system.

In 1981, Linda with fellow Wichitan Darlene Knorr, founded Roots and Wings to help assure foster children of permanent, loving homes. She also founded CASA (Court Appointed Special Advocates) to advocate for children involved in the court system, and in 1988, founded Pathways, a program for children who live in alcohol or drug-abusive homes.

Among the numerous local, state and national awards she has received Linda has been honored at the White House for her service to others.

In addition to their birth children she and husband Phil adopted and raised seven children of different ages and abilities.

In 2006 following Hurricane Katrina and the flooding of New Orleans, Winona Van Norman reached out to its customers who had been affected by the storm.

Quality Rebore & Ring Service was one of the unlucky machine shops. The shop had been under water for an extended period of time. "Winona helped tremendously," says David Fox. WVN helped rebuild Quality Rebore & Ring Service's CG280 Crankshaft Grinder. "A full day's work at no charge and favorable terms on the parts." This sense of responsibility is at the core of Winona Van Norman's operating principle.

Insist on the high quality and unique affordability that is Winona Van Norman. Contact us today for equipment, parts, support and service.

Flywheel Grinders

Part #	Model	Voltage	Power Head	Auto Feed
868401	FG4000	230V, 60HZ, 1Ph	Not Available	Not Available
868405	FG4000R	230V, 60HZ, 3Ph	Not Available	Not Available
868406	FG4000R	230V, 60HZ, 1Ph	Not Available	Not Available
869000	FG5000	208-230V, 60Hz, 3Ph	No	No
869001	FG5000	230V, 60Hz, 1Ph	No	No
868840	FG5000	208-230V, 60Hz, 3Ph	Yes	No
868841	FG5000	208-230V, 60Hz, 1Ph	Yes	No
868850	FG5000	208-230V, 60Hz, 3Ph	Yes	Yes
868851	FG5000	208-230V, 60Hz, 1Ph	Yes	Yes
868822	FG10000	208-230V, 60Hz, 3Ph	Yes	No
868806	FG10000	208-230V, 60Hz, 3Ph	Yes	Yes



FG4000



FG4000R



**FG5000
FG10000**

Solid cast iron, rugged design, exclusive cast in table support and industrial quality gear motor direct-table drive for constant torque are features found only in the FGs from Winona Van Norman. The FG Series will grind all your work pieces from the smallest automotive to the largest heavy duty.

Setup is extremely fast and accurate.

Grinds most automotive and light truck flywheels in 5 - 10 minutes - slightly longer for the Heavy Duty stepped flywheels.

The FGs cost just a few dollars per day to own, take very little floor space, and last for many years. The FGs are an excellent investment!

Supply costs are minimal and labor costs are low since a skilled machinist is not needed to operate the WVN FGs.

Contact Winona Van Norman to get your own FG Series flywheel grinder. We will help you find the options and equipment you need.

order now

1-800-533-8008

Phone: 316-219-3500 Fax: 316-219-3510



FG5000 and FG10000 Standard Equipment

Item #	Part #	Description
1	801064	Centering Cone Bolt 1.875"(47.6mm)
2	801065	Centering Cone Bolt 2.375"(60.3mm)
3	801066	Centering Cone Bolt 3.375"(87.8mm)
Centering Cones		
4	801072	1.00"-1.750"(25.4-44.5mm)
5	801074	1.312"-2.00"(33.3-50.8mm)
6	801076	1.750"-2.50"(44.5-63.5mm)
7	801793	2.00"-2.625"(50.8-66.7mm)
8	801078	2.250"-3.00"(57.2-76.2mm)
9	801080	2.750"-3.50"(69.9-88.9mm)
10	801090	Flange Adaptor 3.00"(76.2mm)
11	801092	Flange Adaptor 4.00"(101.6mm)
12	801094	Flange Adaptor 5.00"(127.0mm)
13	801097	Flange Adaptor 5.875"(149.2mm)
14	812471	Wheel Spacer 1.50"(38.1mm)
15	801128	Grinding Wheel 4"(101.6mm) Flaring
16	801112	Grinding Wheel 6"(152.4mm) Flaring

Item #	Part #	Description
17	801130	Grinding Wheel 6"(152.4mm) Flaring
18	801188	Lower Wheel Flange
19	801744	E-Z Lok Inserts(2)
20	801152	Leadscrew Lubricant
21	830001	Coolant Additive, 1 Qt(0.946 liters)
22	801155	Table Lubricant, 2 Qts(1.892 liters)
23	803321	Leveling Bolts(4)
24	803025	Leveling Bolt Lock Nuts(4)
25	803058	Leveling Pads(4)
26	863745	E-Z Lok Insert Extractor
27	801373	Table Oil Level Gage
28	801732	T-Handle Hex Wrench
29	801737	Wrench Set
30	801645	Wheel Mounting Bolt 2.750"(69.9mm)
31	802081	Wheel Mounting Bolt 2.50"(63.5mm)
32	801599	Wheel Mounting Bolt 1.250"(31.8mm)
33	801610	Wheel Mounting Bolt 1.00"(25.4mm)
34	801312	O-Ring

Stone Grinding Wheels

Hardness	Part #:	Size	Color	Workpiece/Hardness/Material
HARD	868701	3.00" X 2.00" X 1.25"	GRAY	For crankshaft mounting flanges, pressure plate surfaces, automatic trans., pump bodies and covers, straight sided wheel <i>(Requires 868697 Mounting Flange)</i>
HARD	801130	6.00"(4.50" X 2.50" X 1.25")	BLACK	General purpose, for cast iron and medium steel
HARD	801130XL	6.00"(4.75" X 3.00" X 1.25")	BLACK	General purpose, for cast iron and medium steel
MEDIUM	801132	6.00" X 2.50" X 1.25"	RUBY	General purpose, for cast iron and medium steel, straight sided wheel
MEDIUM	863332	4.00"(3.00" X 2.00" X 1.25")	WHITE	Best for aluminum
MEDIUM	801128	4.00"(3.00" X 2.00" X 1.25")	BLACK	For small imported flywheels. Best for cast iron and medium steel
MEDIUM	801112	6.00"(4.50" X 2.50" X 1.25")	BLACK	Some cast iron and ductile iron.
MEDIUM	868530	4.00"(3.00" X 2.00" X 1.25")	WHITE	Premium, mild steel, hardened steel
SOFT	801116	6.00"(4.50" X 2.50" X 1.25")	WHITE	Best for billet steel
SOFT	868623	4.00"(3.00" X 2.00" X 1.25")	BLUE	General purpose, soft-hard flywheels
SOFT	801138-1	3.00"(2.25" X 1.25" X 1.25")	WHITE	Ideal for heat sensitive material. Mild steel
SOFT	801138	3.00"(2.25" X 1.25" X 0.75")	WHITE	Ideal for heat sensitive material. Mild steel <i>(Requires 801173 Mounting Adapter)</i>



Stone Grinding Wheels

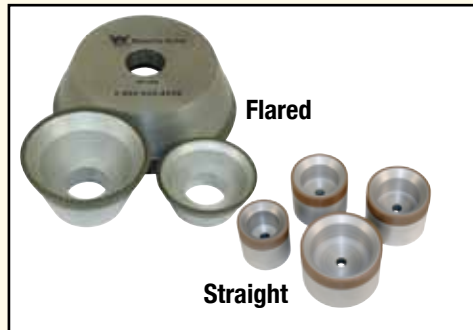

Superabrasive Grinding Wheels



Superabrasive Grinding Wheels, Graphite

Superabrasive Grinding Wheels

Part #	Size	Description	Workpiece/Hardness/Material
801120C	2.00" Diameter	CBN flared sides	General purpose, for cast iron and medium steel
801128C	3.00" Diameter	CBN flared sides	General purpose, for cast iron and medium steel
863332C	4.00" Diameter	CBN flared sides	General purpose, for cast iron and medium steel
801130C	6.00" Diameter	CBN flared sides	General purpose, for cast iron and medium steel
801130CX	6.00" Diameter	CBN flared sides	Best for billet steel
801130D	6.00" Diameter	Diamond flared sides	Hard spray coated flywheels
801105C	2.00" Diameter	CBN straight sides	General purpose, for cast iron and medium steel
801106C	2.25" Diameter	CBN straight sides	General purpose, for cast iron and medium steel
801108C	3.00" Diameter	CBN straight sides	General purpose, for cast iron and medium steel
801110	0.50" X 0.50" X 6.00"	CBN Dressing Stick	Removes light metal loading from superabrasives
801107C	2.50" Diameter	CBN straight sides	General purpose, for cast iron and medium steel
801130CG	6.00" Diameter	CBN flared sides	Heavy graphite - Best for billet steel
801123C	5.00" Diameter	CBN flared sides	General purpose, for cast iron and medium steel
801123CG	5.00" Diameter	CBN flared sides	Heavy graphite - Best for billet steel

Radius Cutter Assembly

Item #	Part #	Description
KIT #	862527	Radius Cutter Assembly
1	801597	SHCS .375-16 x .750 (2)
2	803020	HHCS .500-13 x 1.750 (3)
3	808405	Boring Bar, 1.5"(38/1mm) Dia.
4	808406	Boring Tool
5	808407	SSS .312-18 x .500
6	808840	Washer .562 x 1.375 (3)
7	801199	Spacer, Power Column Washer(3)
8	862128	Mounting Plate



Replaceable Radius Cutter Tip Holder

Item #	Part #	Description
1	808406-1	Radius Cutter Tip Holder
2	808406-2	Cutter Tip
3	862115	Titanium Coated Cutter Tip
4	862116	Replacement Torx Screw



Dial Indicator Kits

Item #	Part #	Description
KIT #	862783	Dial Indicator/Indicator Bar Set
1A	801317	Mounting Adapter(not shown)
2A	801319	Dial Indicator
3A	801320	Indicator Bar
4A	801321	Spacer
5A	801322	Covex Point(not shown)
6A	801620	SSS .250-20 x .250(not shown)
7A	805599	SHCS .375-16 x 3.25 Long
8A	862782	Dial Indicator Magnetic Base
9A	801651	.250-28 Jam Nut(not shown)
KIT #	801324	Indicator Bar Kit
1B	801191	Knob
2B	801325	Indicator Bar
3B	801329	Hex Nut .250-20, Jam(2)
4B	801333	Indicator Point, 1
5B	801704	Indicator Point, 2.5
6B	802052	Foot Assembly, .500(2)
7B	802053	Foot Assembly, 1.00(2)

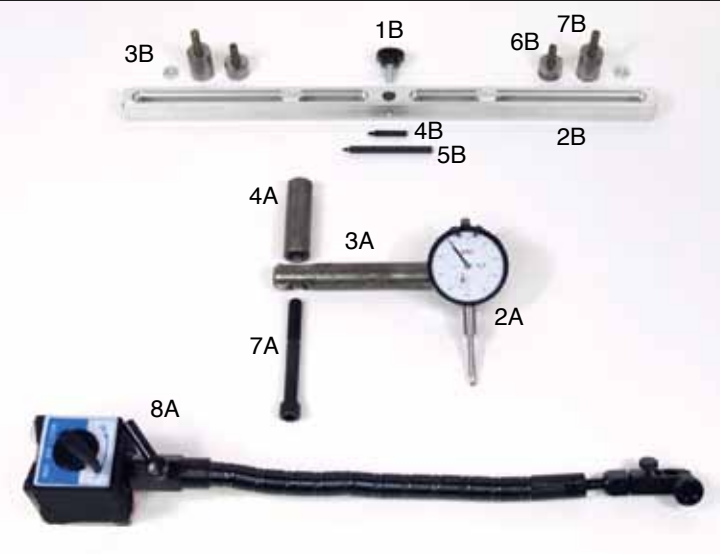

PG1232 Platen Grinder

For engine and transmission rebuilders.

- Removable belt guards
- Efficient 944 fm belt speed
- 32" length capacity
- Hard, precision ground platen for long life and flat surfaces
- Removable dust tray
- Adjustable quick tensioners
- Covered foot switch control
- 40, 60 and 80 grit belts available



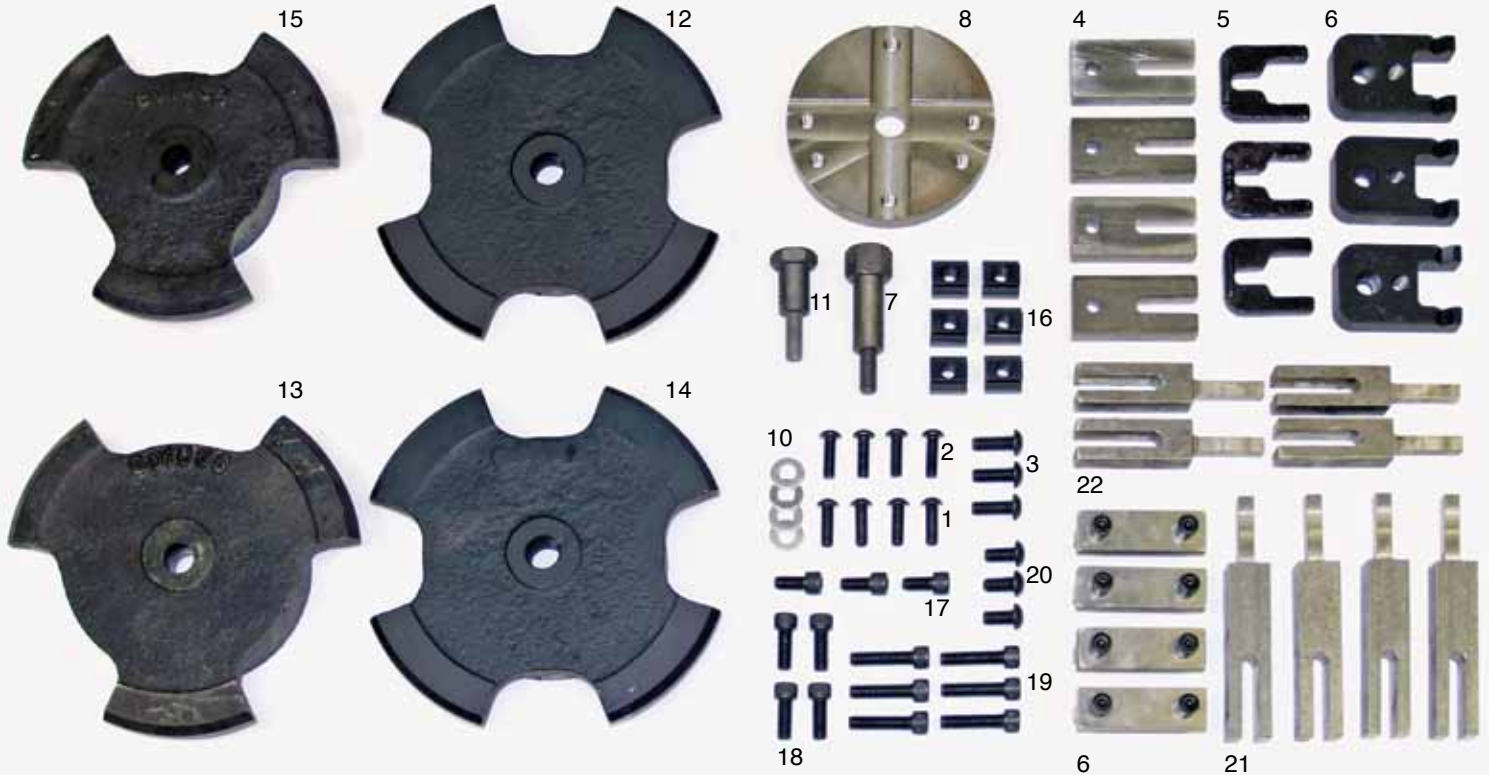

Clutch Tooling Kit

Item #	Part #	Description	Item #	Part #	Description
KIT #	801040	Clutch Tooling Kit	11	801030	Hold Down Bolt Assembly
1	801001	BHCS 0.312"-24 x 1.000"(4)	12	801032	Clutch Adapter, 9.5
2	801002	BHCS 0.312"-18 x 1.000"(4)	13	801034	Clutch Adapter, 8.75
3	801003	Clutch Diaphragm Fastener (4)	14	801036	Clutch Adapter, 9.0
4	801005	BHCS 0.375"-16 x 0.750"(3)	15	801038	Clutch Adapter, 7.5
5	801007	Clamp Plate	16	801058	Tee Nut, 0.375"-16 x 0.500"(6)
6	801009	V-Plate	17	801597	SHCS 0.375"-16 x 0.750"(3)
7	801012	Hold Down Bolt Assembly	18	801610	SHCS 0.375"-16 x 1.000"(4)
8	801016	Center Plate	19	801657	SHCS 0.375"-16 x 1.500"(6)
9	801019	Parallel Block Assembly	20	860487	BHCS 0.375"-16 x 1.000"(3)
10	801023	Flat Washer(4)	21	804786	Long Finger, 6"
			22	804787	Long Finger, 4.5"

Flywheel Dowel Pin Puller Kit

Item #	Part #	Description
KIT #	868478	Popular Automotive Domestic and Import Kit
1	868844	Slide hammer
2	868845	Slide Rod
3	868846	Tightening Sleeve
4	868856	1/4" Collet(6.35mm)
5	868857	5/16" Collet(7.93mm)
6	868858	3/8" Collet(9.53mm)
7	868859	7/16" Collet(11.10mm)
8	868862	5mm Collet
9	868863	6mm Collet
10	868847	Removal Stand
11	868848	Storage Case
Optional Parts		
	868855	3/16" Collet(4.75mm)
	868860	1/2" Collet(12.7mm)
	868889	9/16" Collet(14.28mm)
	868861	4mm Collet
	868864	8mm Collet
	868865	10mm Collet
	868477	0"-4" Depth Micrometer(0-101.6mm)



Grinding Wheel Dressers & Replacement Cutter

WVN #	Description	Applications
801170-1	Dresser, 2.5"OD x 1.5" ID x 0.0625" Wide	VN, Lempcoc, Storm RT-7Y, 17Y
801170-2	Dresser, 2.375" OD x 1.5" ID x 0.0938" Wide	Peterson (12mm Shaft)
801170-3	Dresser, 2.375" OD x 1.5" ID x 0.0938" Wide	Kwik-Way
801170	Dresser, 1.25" D x 0.313" ID x 0.0625" Wide	WVN SM2000, 4000, 5000, 6000C, 6000A, MG3000, 3850
801170-4	Dresser, 2.375" OD x 1.125" x 0.125" Wide	Peterson & DCM
801170-5	Dresser, Hand Held	Hand Held for all machines
801169-1	Dresser, 14 Stars, 1.75" x 0.58"	Used with 801170-1
801169-2	Dresser, 8 Stars, 2" x 1.5" x 0.028"	Used with 801170-2 and 801170-3
801169	Dresser, 7 Stars	Used with 801170
801169-4	Dresser, 5 Stars, 1.624" x 0.031"	Used with 801170-4
801101	Dresser Stone, 1.5" x 0.313" x 0.625"	Used with 801170-5



Heavy Duty Universal Centering Cone Kit

Item #	Part #	Description
KIT #	810788	Heavy Duty Universal Centering Cone & Spacer Set
1	801058	Tee Nut .375-16 x .500
2	801059	Hex Stool, 0.5"(12.7mm)
3	868712	Hex Stool, 1.0"(25.4mm)
4	801082	Centering Cone, 4.0"(101.6mm)
5	801084	Centering Cone, 4.5"(114.3mm)
6	801086	Centering Cone, 5.0"(127.0mm)
7	801189	Wheel Spacer, 1"(25.4mm)

Item #	Part #	Description
8	801190	Wheel Spacer, 2"(50.8mm)
9	801206	SHCS .375-16 x 2.25
10	801597	SHCS .375-16 x .75
11	801599	SHCS .375-16 x 1.25
12	801623	Stud .375-16 x 2.875
13	802080	SHCS .375-16 x 2.00
14	805599	SHCS .375-16 x 3.25
15	812472	SHCS .375-16 x 3.00
16	867799	Centering Cone Bolt, 4.25"



Heavy Duty Centering Adapter Set

Item #	Part #	Description
KIT#	868018	Heavy Duty Centering Adapter Set
1	865737	Ford/Cat 205, 2.040"(51.8mm)
2	865738	Mack 305, 2.435"(61.8mm)
3	865739	Ford Truck, 2.495"(63.4mm)
4	865740	Cum/GMC 306, 2.830"(71.9mm)
5	865741	Ford 307, 3.149"(79.9mm)
6	865742	Ford Truck, 3.255"(82.7mm)



VW/Universal Flywheel Kit

Item #	Part #	Description
KIT #	868549	VW/Universal Flywheel Kit
1	801058	Tee Nut 0.375"-16 x 0.500"(3)
2	801202	Centering Cone
3	801203	Tooling Support Block(3)
4	801204	Tooling Clamp(3)

Item #	Part #	Description
5	801206	SHCS 0.375-16 x 2.250"(3)
6	806417	SHCS 0.437-14 x 0.750"
7	803326	Flat Washer, 0.375"(3)
8	801657	SHCS 0.375-16 x 1.500"(3)
9	801610	SHCS 0.375-16 x 1.000"(3)



VW Small Bore Flywheel Kit

Item #	Part #	Description
KIT #	810790	Small Bore/VW Centering Cone Set
1	801069	VW Rabbit Centering Cone, 1.380"
2	801070	Centering Cone, 1.375"
3	801095	VW Flange Adapter
4	801596	FSHCS, 0.437"-14 x 2.00"
5	801628	SHCS, 0.437"-14 x 1.50"
6	868699	FSHCS, 0.437"-16 x 2.50"
7	868714	SHCS, 0.437"-14 x 2.25"



Transmission Pump Kit

Item#	Part #	Description	Item#	Part #	Description
KIT#	863333	ATP5000 Transmission Pump Kit	15	863211	Centering Disc
1	863207	Centering Hub, Pump Body	16	863330	Counter Boring Tool
	863329	Adaptor Disc 0.910"	17	810520	Dressing Stick, Hand Held
2	863223	Adaptor Disc 2.039" ID	18	863215	Flanged Nut .5"(12.7mm)
3	863222	Adaptor Disc 2.121" ID	19	863213	Hold Down Stud
4	863221	Adaptor Disc 2.185" ID	20	801173	Mounting Adapter
5	863220	Adaptor Disc 2.615" ID	21	863331	Peg Board
6	863227	Adaptor Disc 2.723" ID	22	863208	Support Stand
7	863219	Adaptor Disc 2.751" ID	23	863121	Support Tube
8	863226	Adaptor Disc 2.825" ID	24	863216	Tee Handle Wrench
9	863225	Adaptor Disc 2.925" ID	25	863214	Washer, Heavy
10	863218	Adaptor Disc 2.967" ID	26	801189	Wheel Spacer Assembly, 1"(25.4mm)
11	863224	Adaptor Disc 2.980" ID		801190	Wheel Spacer Assembly, 2"(50.8mm)
12	863228	Adaptor Disc 2.057" ID		801138	Grinding Wheel, 3"
13	863209	Alignment Plate		863332	Grinding Wheel, 4"
14	863217	Brass Wire Brush		863210	SHCS .4375"(Qty 4)



Clamp Set

Item#	Part #	Description
KIT#	868493-1	Optional Hold-down Tooling for Floater Plates
1	868496	T-Nuts(4)
2	868497	Fixture Clamps(6)
3	868498	3/16" Hex Keys(2)



Plate Fixture for FG5000

Part #	Description
868706	Clutch Disc Plate Fixture
868706-1	Knurled Screws (3)



Coolant Tank Maintenance

When using stone wheels it is necessary to clean your coolant tank every 50 flywheels. Remove coolant tank and pump and empty, clean and flush. Return pump to tank then slide tank half way in, add one quart of 801140 coolant concentrate and fill with water. Slide tank back into grinder.

Rinse Nozzle Kit

Part #	Description
869084	Rinse Nozzle Kit - FG5000

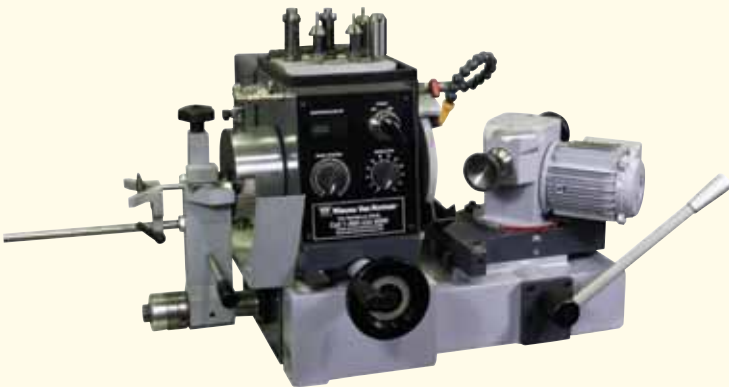

VRX Valve Refacer - Part# 350001

High Precision for Low Cost.
 Variable Speed Direct Drive Motors
 Valve Face Angle Range from 15° To 90°
 Carriages Slide on Dovetail Guides
 Collet System Provides Tight Concentricity
 Total Indicated Runout for Valve Face Concentricity .0002"
 Two Sizes of Ball Chucks, High Precision, .0002" TIR

Diamond Dresser

Part #	Description
868953	Diamond Dresser Arm w/Diamond



Head Tilt Setting Kit

Item#	Part #	Description
KIT#	868632	Head Tilt Setting Kit
1	801317	Mounting Adapter(not shown)
2	801319	Dial Indicator
3	801320	Indicator Bar
4	801321	Spacer
5	801620	SSS .250-20 x .250(not shown)
6	805599	SHCS .375-16 x 3.25 Long



E-Z Lok Insert and Extractor

Part #	Description
801744	E-Z Lok Insert
863745	E-Z Lok Insert Extractor



Table Spindle Maintenance

The replaceable E-Z Lok insert is used to extend the life of the table spindle. Any damage to threads will occur to the inexpensive insert. Once a month remove the insert to check for wear and coat with anti-seize. This will insure that the insert is replaced when necessary and allow for a thorough removal of all grit and any rust.

The extractor is a standard part and supplied with the machine. The special design accommodates easy removal of the insert with a wrench or socket.

Flywheel Step Comparator

Item#	Part #	Description
KIT#	869267	Flywheel Step Comparator
1	869282	2" Standard Block
2	869269	1" Standard Block
3	801191	Knob
4	801333	Indicator Point 1.00"
5	801704	Indicator Point 2.5"
6	801319	Dial Indicator
7	801325	Indicator Bar

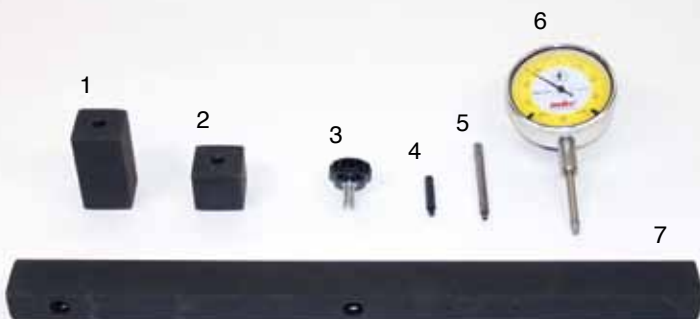

Magnetic Chucks

Part #	Description
869341	Magnetic Chuck Kit - 9.25"
869342	Magnetic Chuck Kit - 12.50"
869343	Magnetic Chuck Kit - 16.00"



Racing Package FG4000R Tooling (Std with FG4000 Racing)

Item#	Part #	Description	Item#	Part #	Description
KIT#	868704	Racing Package tooling	17	060070	3/16" Hex Wrench
1	812471	Wheel Spacer 1.50" (38.10mm)	18	060100	1/4" Hex Wrench
2	801190	Wheel Spacer 2.00" (50.80mm)	19	868498	T-Handle Hex Wrench (1/4) (2)
3	868723	Wheel Spacer 4.00" (101.6mm)	20	868501	T-Handle Hex Wrench (3/18)
4	863332C	4.00" Diameter - CBN flared sides	21	801732	T-Handle Wrench (5/16)
5	801130C	6.00" Diameter - CBN flared sides	22	801744	E-Z Lock Insert (2 included)
6	868697	3" Wheel Mounting Flange	23	863745	E-Z Lock Insert Extractor
7	801188	6" Wheel Mounting Flange	24	868532-1	Head Tilt Setting Kit
8	017024	Wheel Mounting Bolt, 1.00" (25.4mm)	26	868706	Clutch Disc Mounting Plate
9	017055	Wheel Mounting Bolt, 2.50" (63.5mm)	27	868707	Pressure Plate Mounting Ring
10	017055	Wheel Mounting Bolt, 2.75" (59.85mm)	28	868710	Flywheel Mounting Ring
11	869238	Wheel Mounting Bolt, 4.50" (114.3mm)	29	801312	O-Ring
12	869239	Wheel Mounting Bolt, 4.25" (107.95mm)	30	801373	Oil Level Gauge
13	060018	3/8" Hex Wrench	31	801152	Lead Screw Lubricant Grease
14	060020	5/16" Hex Wrench	32	801155	Table Lubricant, 1 Qt. (.946 liter) (2)
15	060054	1/8" Hex Wrench	33	005794	Tool Box
16	060062	5/32" Hex Wrench		868554	Shop Vac Adapter Assembly (Factory Only)

Custom Flywheel Mounting
Rings Available Upon Request



Flywheel Grinding Coolant

Part #	Description
801140	Coolant Additive, 1 Qt
801141	Coolant Additive, 1 Gallon
801142	Coolant Additive, 5 Gallon
813068	Coolant Additive, 55 Gallon

Flywheel Grinding Coolant

With years of testing, Winona Van Norman, has developed a premium grinding coolant. A specially formulated, concentrated coolant blend for use in all types of flywheel grinders. Low odor, easy to mix, increases wheel life, reduces wheel loading and improves work piece surface finish. Maintains a cleaner part and cleaner wheel. When working with vitreous stone wheels clean coolant after 50 flywheels, with CBN clean after 100 flywheels or if wheel begins to load. Blend at 30 parts water to 1 part coolant.



Lubricants and Coolants

Replacement Parts

Part #	Description
810392	Wheel Head Spindle Oil, 1 Gallon
801152	Lead Screw Lubricant, 4 Oz.
801155	Table Lubricant, 1 Qt
801155-1	Table Lubricant, 1 Gallon
801173	Mounting Adapter 1.75" to .75"
801188	Lower Wheel Flange
868697	3" Mounting Flange
801312	O-Ring
801373	Table Oil Level Gage
812471	Wheel Spacer 1 1/2"
801065	Centering Cone Bolt 2.375"(60.3mm)
801066	Centering Cone Bolt 3.375"(87.8mm)
801067	Centering Cone Bolt 3.5"(88.9mm)
867116	Coolant Pump Assembly, 230V
862176	Coolant Pump Assembly, 115V
868397	Flexible Coolant Hose(FG4000)
801313	Flexible Coolant Hose(FG5000/FG10000)
868543	Radius Cutter Assembly(FG4000)
865166	Shaft and Disc Assembly – 9.750" long
801286	Shaft and Disc Assembly – 10.750" long
861946	Shaft and Disc Assembly – 11" long
868553	Carbide Tool for Radius Cutter (FG4000)
868720	Optional Coolant System for FG4000R
869311	Loadmeter for FG4000 3Ph
869312	Loadmeter for FG5000 3Ph
869313	Loadmeter for FG4000 & FG5000 1Ph
869314	Loadmeter for FG10000 3Ph
869330	ATP6000 Series Allison Kit (FG5000/FG10000 only)
862280	Coolant Switch – 2 position
862281	Start Switch
862282	Stop Switch
862314	Emergency Stop Switch
862513	Power Column On/Off
860679	DC Controller



Replacement pumps



Replacement Shafts



Replacement Switches



The most trusted name in
advanced technology for engine rebuilders.

*Shown below, left to right:
SMX Surface Grinder, VRX
Valve Grinder, PG 1232 Platen
Grinder, VSGX-A Seat & Guide
Machine, and VBX 300 CNC
Cylinder Boring Machine*



© Copyright 2009, Winona Van Norman. Winona Van Norman reserves the right to change product specifications without notice



710 E. 17th St. • Wichita, Kansas 67214